

250/390 Series Twin Model

Model:
C25055-21TP-24TP
C39055-07, 08

OPERATION

SERVICE

PARTS

CARE

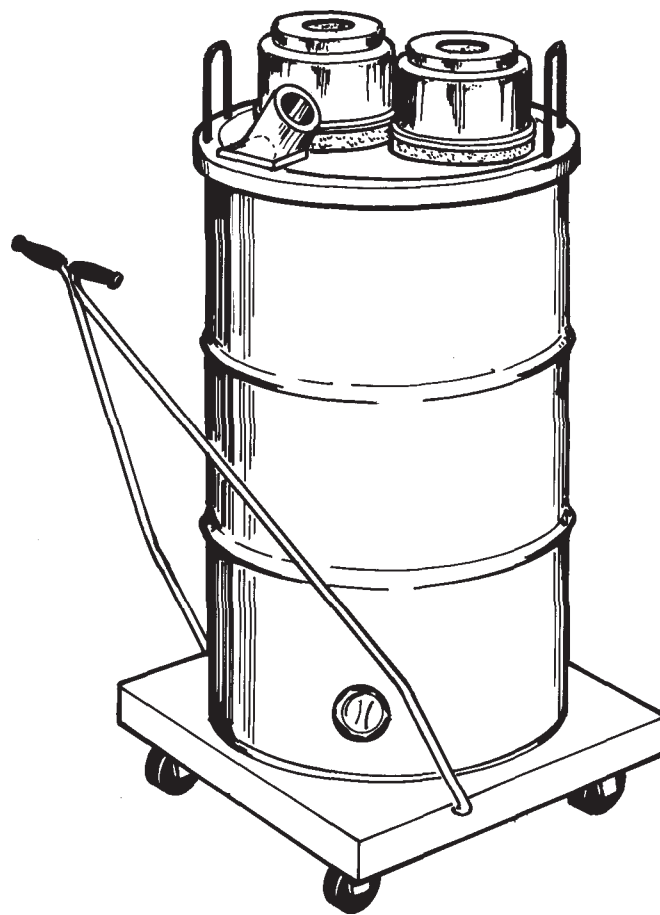

Revised 2/94

Minuteman[®]

FOR COMMERCIAL USE ONLY

IMPORTANT SAFETY INSTRUCTIONS

When using an electrical appliance, basic precautions should always be followed, including the following:

READ ALL INSTRUCTIONS BEFORE USING

WARNING - To reduce the risk of fire, electric shock, or injury:

- Do not leave appliance when plugged in. Unplug from outlet when not in use and before servicing.

WARNING

To reduce the risk of electrical shock - Do not expose to rain. Store indoors.

- Never allow children or untrained adults to operate this equipment.
- Keep the area of operation clear of all persons, particularly small children, and pets. Keep bystanders at least 25 feet away from the area of operation.
- Use only as described in this manual. Use only manufacturer's recommended attachments.
- Do not use with damaged cord or plug. If appliance is not working as it should, has been dropped, damaged, left outdoors, or dropped into water, return it to a service center.
- Do not pull or carry by cord, use cord as a handle, close a door on cord, or pull cord around sharp edges or corners. Do not run appliance over cord. Keep cord away from heated surfaces.
- Do not unplug by pulling on cord. To unplug, grasp the plug, not the cord.
- Do not handle plug or appliance with wet hands.
- Do not put any object into openings. Do not use with any opening blocked; keep free of dust, lint, hair, and anything that may reduce air flow.
- Keep hair, loose clothing, fingers, and all parts of body away from openings and moving parts.
- Do not pick up anything that is burning or smoking, such as cigarettes, matches or hot ashes.
- Do not use without dustbag and/or filters in place.
- Turn off all controls before unplugging.
- Use extra care when cleaning on stairs.
- Do not use to pick up flammable or combustible liquids such as gasoline or use in areas where they may be present.
- Connect to a properly grounded outlet only. See grounding instructions.

SAVE THESE INSTRUCTIONS

INSPECTION

Carefully unpack and inspect your machine for shipping damage. Each unit is tested and thoroughly inspected before shipment, and any damage is the responsibility of the delivery carrier who should be notified immediately.

ELECTRICAL - 115 Volt

This machine is designed to operate on a standard 15 amp, 115 volt, 60 hz, AC circuit. Voltages below 105 volts AC or above 125 volts AC could cause serious damage to the motor.

ELECTRICAL - 240 Volt

This machine is designed to operate on a standard 16 amp, type L fused 230 volt, 50 hz, AC circuit. Voltages below 200 volts AC or above 250 volts AC could cause serious damage to the motor. I.E.C. Class I.

WARNING

Electric motors can cause explosions when operated near explosive materials or vapors. Do not operate this machine near flammable materials such as solvents, thinners, fuels, grain dust, etc.

GROUNDING INSTRUCTIONS

This appliance must be grounded. If it should malfunction or breakdown, grounding provides a path of least resistance for electric current to reduce the risk of electric shock. This appliance is equipped with a cord having an equipment-grounding conductor and grounding plug. The plug must be plugged into an appropriate outlet that is properly installed and grounded in accordance with all local codes and ordinances.

DANGER - Improper connection of the equipment-grounding conductor can result in a risk of electric shock. Check with a qualified electrician or service person if you are in doubt as to whether the outlet is properly grounded. Do not modify the plug provided with the appliance -- if it will not fit the outlet, have a proper outlet installed by a qualified electrician.

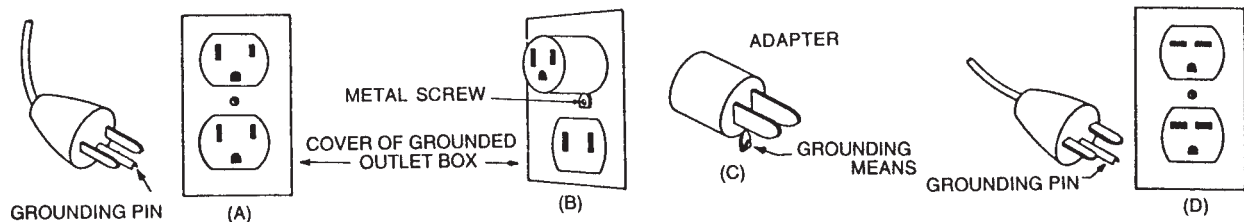

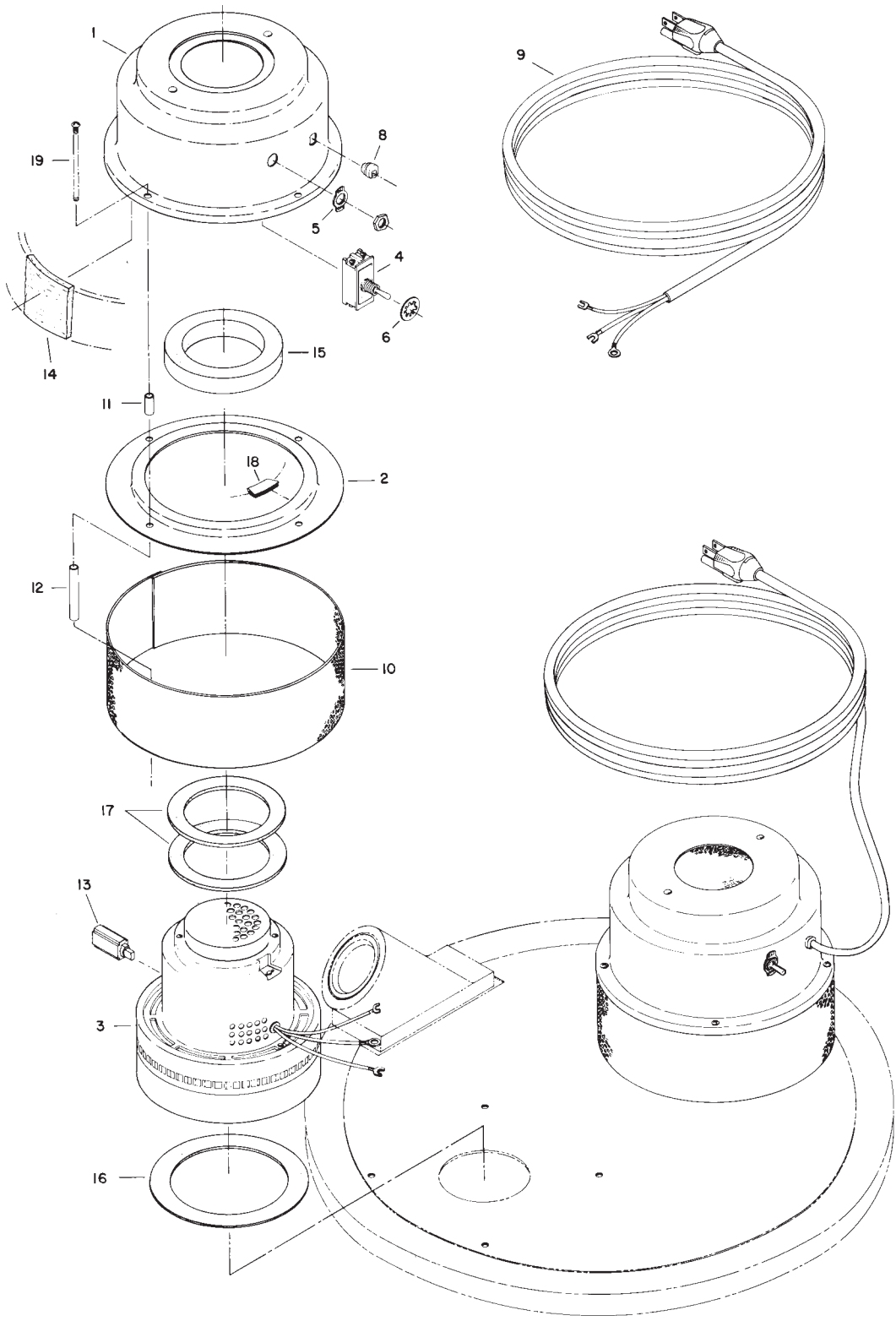

PARTS LISTING

ITEM NO.	PART NO.	QTY.	DESCRIPTION
1	750414	2	Motor dome
2	255046PLT	2	Motor retainer for item 3
2A	750000	2	Motor retainer for item 3A
3	255039	2	Vacuum motor 250 115V
3A	255040	2	Vacuum motor 250 240V
3B	380001	2	Vacuum motor 390 115V
3C	380054	2	Vacuum motor 390 240V
4	380002	2	Switch 1.5 H.P.
5	101020	2	Plate on/off
6	711556	2	Washer lock 1/2
8	100028	2	Strain relief
9	381020	2	Power cord model C81455-03
9A	150001	1	Cord set 240V model
10	761207	2	Screen model C81455-03
10A	761032	2	Screen model C80355-04, 05
11	761946	8	Spacer short
11A	255045	8	Spacer short for C80355-04, 05
12	252101	8	Spacer long
12A	252007	8	Spacer long for C80355-04, 05
13	255008	2	Carbon brush for item 3
13A	380028	2	Carbon brush for item 3A
14	380040	1	Felt insulation
15	101005	2	Gasket, rubber for item 3
15A	380064	2	Gasket, foam for item 3A
16	480049	2	Gasket motor for item 3
16A	380035	2	Gasket motor for item 3A
17	380035	2	Gasket motor
18	255030	2	Gasket motor retainer
19	710374	8	Screw, MC 10-32 x 4
19A	710373	8	Screw, MC 10-32 x 3.5

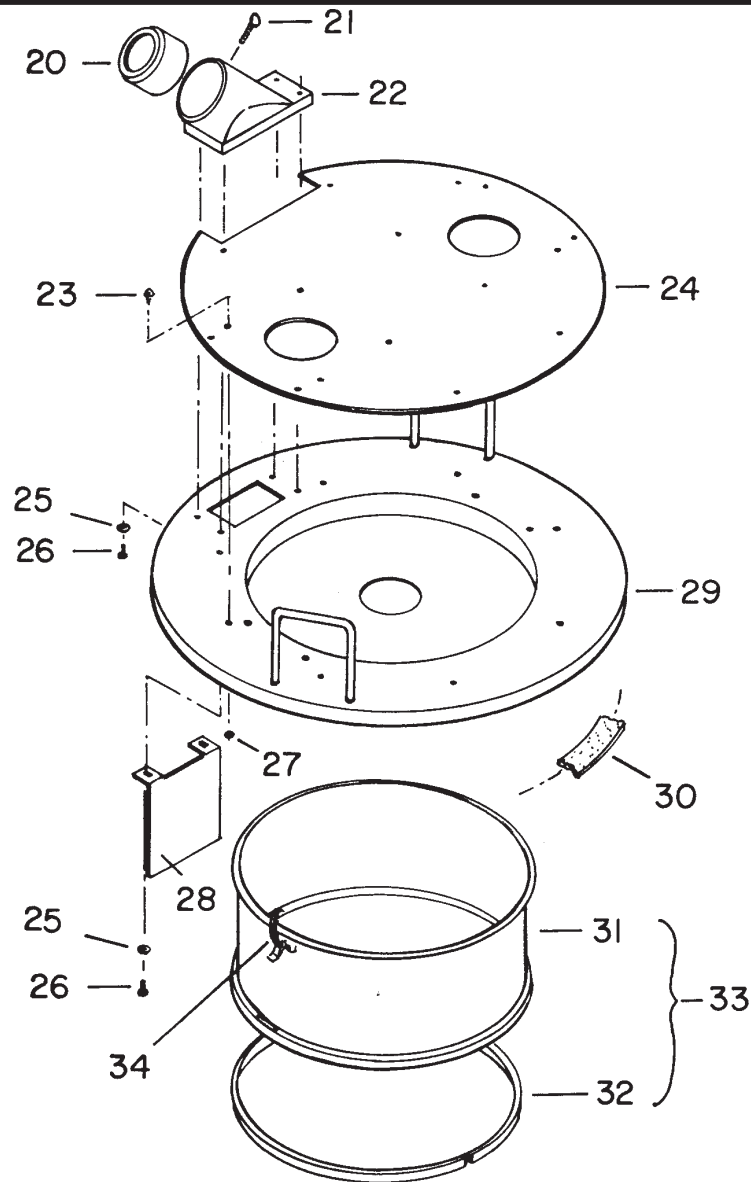

PARTS LISTING

ITEM NO.	PART NO.	QTY.	DESCRIPTION
20	900056	1	Adapter intake
21	712016	1	Thumb screw
22	760008PTD	1	Intake, painted
23	711109	8	SCR-ST-A 12 x .50
24	761949	1	Cover lid weldment
25	711543	12	Washer, helical #10
26	710255	4	SCR-MC 10-32 x .62
27	761481	8	Screw protector
28	760159	1	Splash guard
29	252003	1	Lid weldment with handles
30	806006MCH	1	Lid gasket
31	760033	1	Splash shield no/hardware
32	760165	1	Edging
33	750326	1	Splash shield, complete includes 36, 37, 38
34	761054	2	Latch

CLOTH BAG ASSY COMPLETE
805047

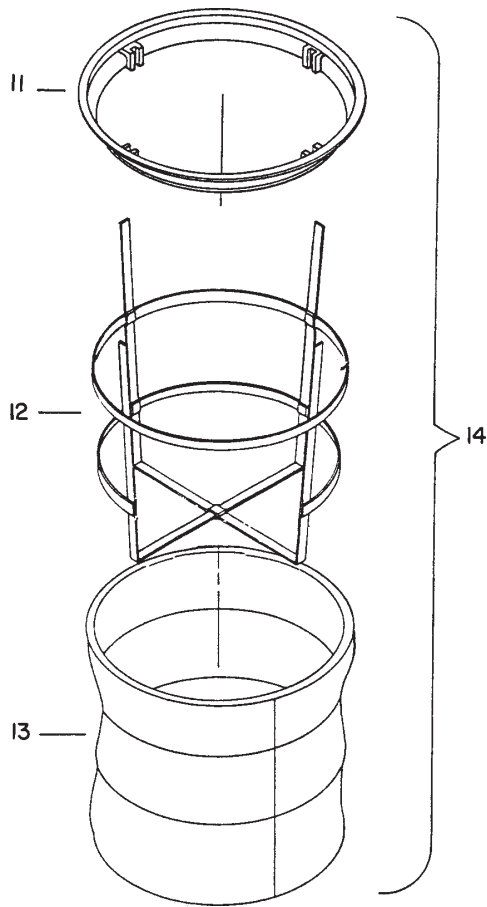

WATER SHUT-OFF ASSY COMPLETE
515003

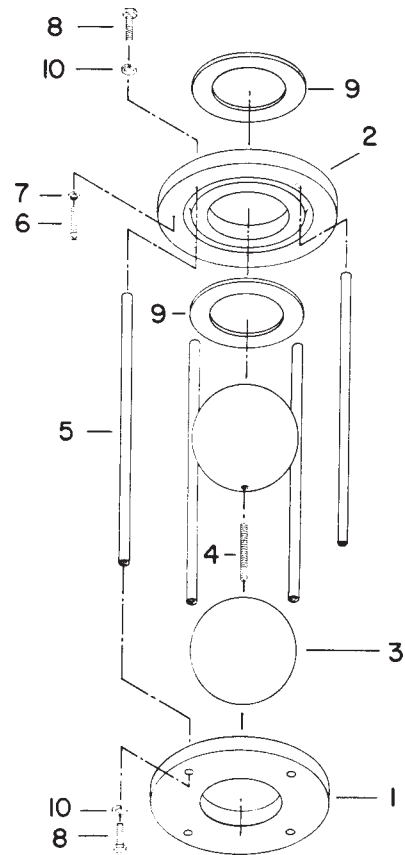

PARTS LISTING

ITEM NO.	PART NO.	QTY.	DESCRIPTION
1	701041	1	Plate, end cap water shut-off
2	701042	1	Plate, end cap water shut-off
3	701016	1	Ball, float 4 dia.
4	701013	1	Stud
5	701012	1	Rod, spacer
6	710359	1	Screw-MC 10-32 x .87-ST PL
7	711543	1	WSR-helical #10
8	711204	1	BLT-HH 1/4-20 x .75 ST PL
9	701015	1	Gasket, 2.25 x 3.50 x .12
10	711544	1	WSR-helical 1/4
11	760131	1	Molded bag ring
12	750097	1	Bag frame
13	805054	1	Cloth bag only
14	805057	1	Assy., bag cloth w/frame
***	515003	1	50 gal. water shut-off

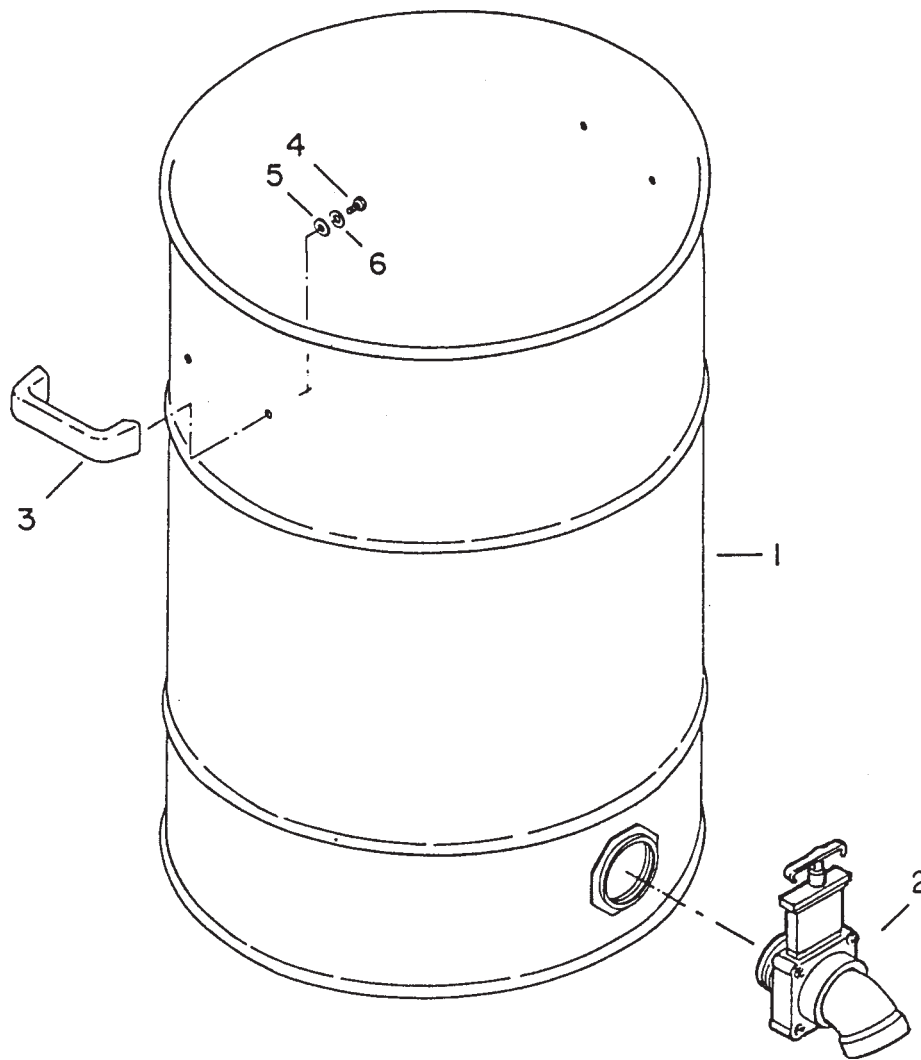

PARTS LISTING

ITEM NO.	PART NO.	QTY.	DESCRIPTION
1	900078PTD	1	Tank 30 gal. PTD less handles
1A	900015PTD	1	Tank 55 gal. PTD no handles
2	900047	1	Dump valve
3	900031POL	2	Handle, tank polished
4	711203	4	BLT-HH 1/4-20 x .62
5	711591	4	Washer, rubber
6	711505	4	WSR, flat 1/4
***	C90007-80		Tank 30 gal. complete
***	805037PKG		Drum liner 30 gal. pkg. 12
***	805046PKG		Drum liner 55 gal. pkg. 12

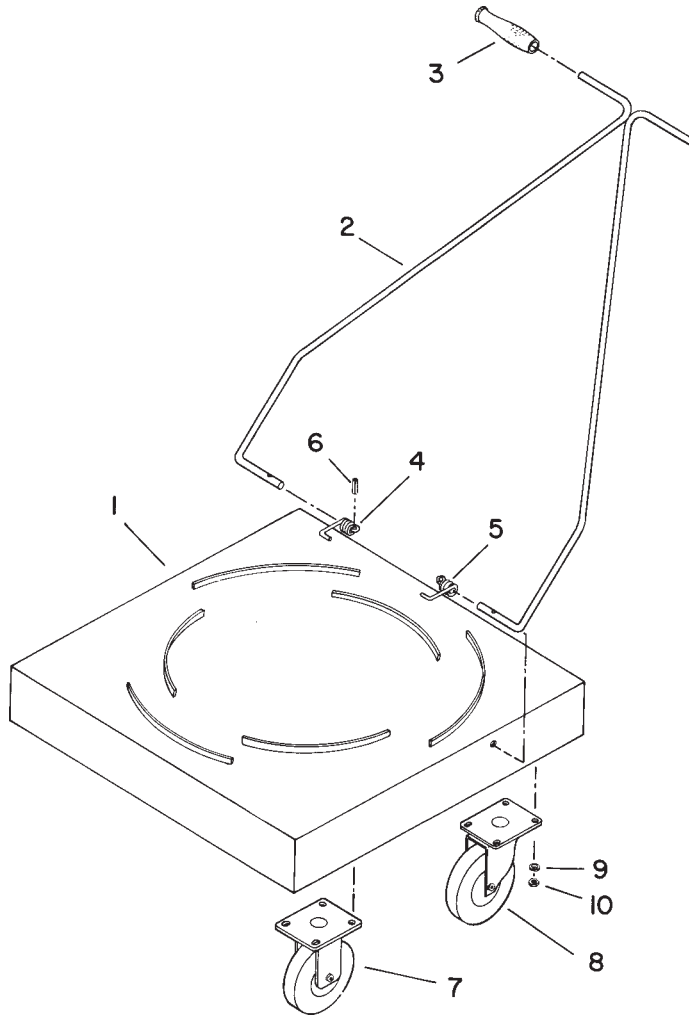

PARTS LISTING

ITEM NO.	PART NO.	QTY.	DESCRIPTION
1	750045	1	Weldment dolly 30/55
2	900051	1	Weldment handle
3	900052	2	Grip handle
4	900080	1	Spring, torsion RH
5	900081	1	Spring LH
6	711642	2	Rollpin
7	761050	2	Caster, rigid 5"
8	761049	2	Caster, swivel 5"
9	711545	16	WSR-helical spr loc 5/16
10	711319	16	Nut-hex 5/16-18 ST PL
***	900048		Dolly cart complete

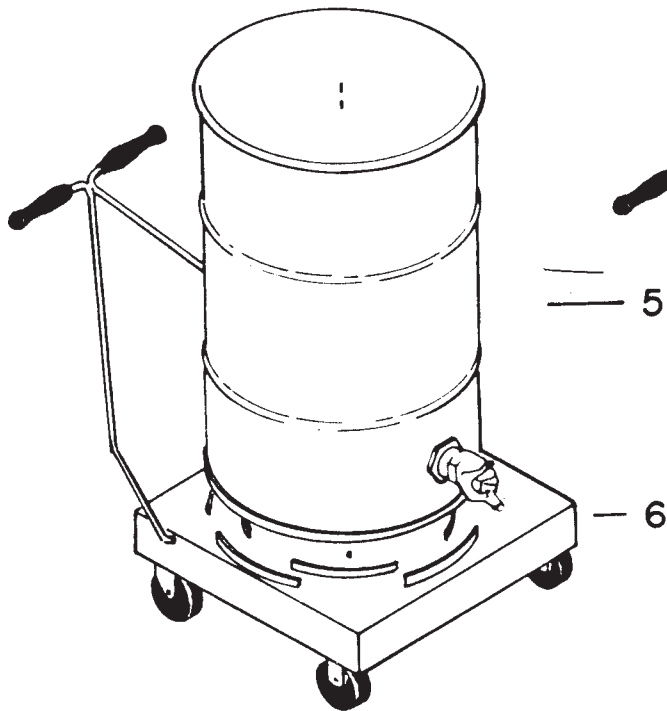
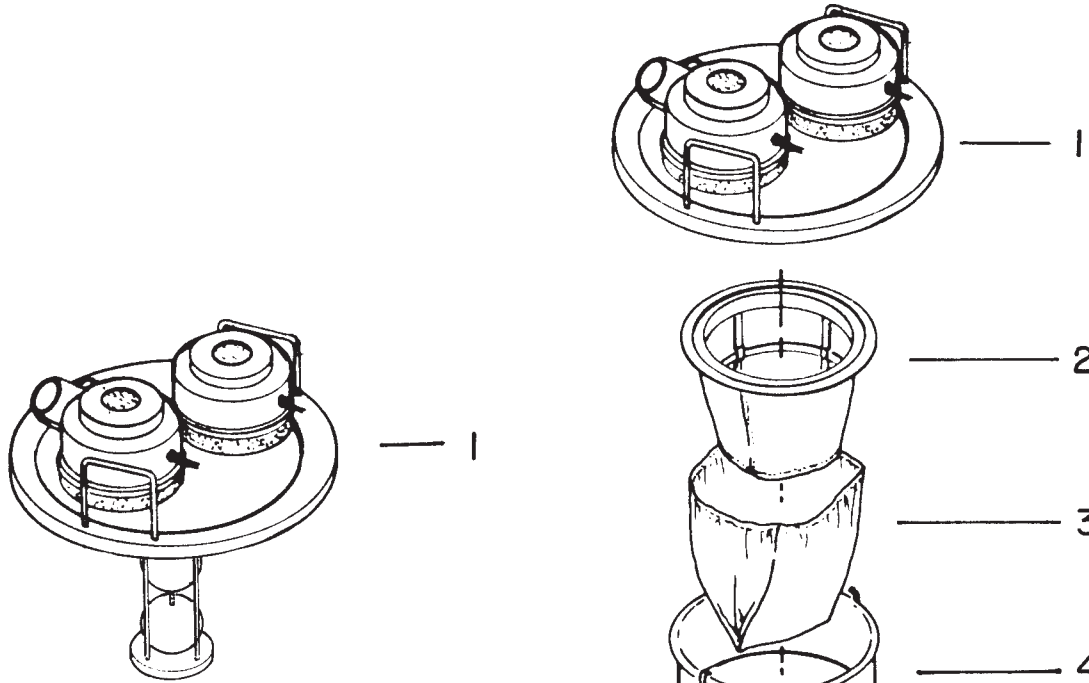

Figure 1

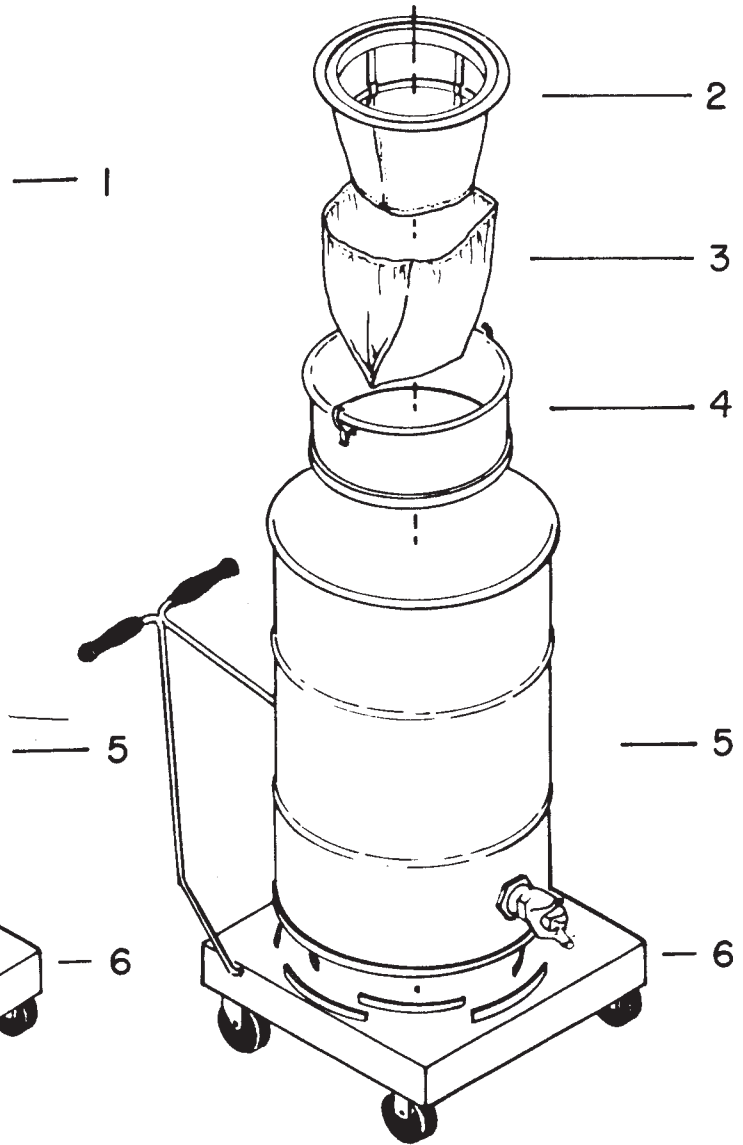

Figure 2

LIMITED WARRANTY

Minuteman International, Inc. warrants to the original purchaser/user that this product is free from defects in workmanship and materials under normal use and service for a period of three years from date of purchase. In addition, Minuteman International, Inc. will, at its option, honor labor warranty claims for the first 12 months from date of sale, provided such claims are submitted through and approved by factory authorized repair stations. Minuteman International, Inc. will, at its option, repair or replace without charge, except for transportation costs, parts that fail under normal use and service when operated and maintained in accordance with the applicable operation and instruction manuals.

This warranty does not apply to normal wear, or to items whose life is dependent on their use and care, such as belts, cords, switches, hoses, rubber parts, electrical motor components or adjustments. Parts not manufactured by Minuteman International, Inc. such as engines, batteries, battery chargers, hydraulic pumps, and tires are covered by and subject to the warranties and/or guarantees of their manufacturers. Please contact Minuteman International, Inc. for procedures in warranty claims against these manufacturers.

Special warning to purchaser — Use of replacement filters and/or prefilters not manufactured by Minuteman International, Inc. or its designated licensees, will void all warranties expressed or implied.

A potential health hazard exists without exact original equipment replacement.

All warranted items become the sole property of Minuteman International, Inc. or its original manufacturer, whichever the case may be.

Minuteman International, Inc. disclaims any implied warranty, including the warranty of merchantability and the warranty of fitness for a particular purpose. Minuteman International, Inc. assumes no responsibility for any special, incidental or consequential damages.

This limited warranty is applicable only in the U.S.A. and Canada, and is extended only to the original user/purchaser of this product. Customers outside the U.S.A. and Canada should contact their local distributor for export warranty policies. Minuteman International, Inc. is not responsible for costs or repairs performed by persons other than those specifically authorized by Minuteman International, Inc. This warranty does not apply to damage from transportation, alterations by unauthorized persons, misuse or abuse of the equipment, use of non-compatible chemicals, or damage to property, or loss of income due to malfunctions of the product.

If a difficulty develops with this machine, you should contact the dealer from whom it was purchased.

This warranty gives you specific legal rights, and you may have other rights which vary from state to state. Some states do not allow the exclusion or limitation of special, incidental or consequential damages, or limitations on how long an implied warranty lasts, so the above exclusions and limitations may not apply to you.

Minuteman[®]

World Headquarters
Minuteman International, Inc.
111 South Rohlwing Road
Addison, Illinois 60101

Minuteman Canada, Inc.
2210 Drew Road
Mississauga, Ontario
L5S 1B1

(630) 627-6900
FAX (630) 627-1130

(905) 673-3222
FAX (905) 673-5161

987885
Printed in U.S.A.